

| |
|--------------------|
| Identity Symbol |
|--------------------|

Name _____ School grade _____ Date _____

48

CIRCLE THE CORRECT ANSWER

1. The major five finger pattern is (**WWHW** or **WHHW**).
2. Ludwig van Beethoven was from (**England** or **Germany**).
3. A (**half** or **whole**) step is from one key to the next key with a key in between.
4. When you notate, or write down music which you made up, it is a (**composition** or **combination**).
5. Frederic Chopin wrote many beautiful works for the (**piano** or **celesta**) in the Romantic Era.
6. "Farmer in the Dell" is an example of (**a folk song** or **an opera**).
7. A (**measure** or **motive**) is a musical idea or a small, striking melodic pattern.
8. (**Folk songs** or **The Nutcracker**) is a ballet written by Tchaikovsky.
9. Bach, Scarlatti, and Handel were all born in 1685 and lived in the (**Baroque** or **Contemporary**) Era.
10. Robert Schumann composed (**The Happy Farmer** or **The Happy Rancher**) in *Album for the Young*.
11. The flute is a (**woodwind** or **brass**) instrument.
12. In a ballet, (**dancers** or **instruments**) tell stories with their feet, arms and bodies.
13. Improvisation is when you (**make up** or **practice**) music.
14. Schumann was a composer from the (**Baroque** or **Romantic**) Era.
15. You can build a major or minor pattern on (**only black keys** or **any key**) on the piano.
16. The scale made of ONLY half steps is called the (**chromatic** or **major five finger pattern**) scale.
17. "Chinese Dance" and ("**Dance of the Reed Flutes**" or "**Dance of the Crickets**") are from *The Nutcracker*.
18. Notes move up or down the staff by steps, skips or (**repeats** or **leaps**).
19. Ludwig van Beethoven used ("**Ode to Joy**" or "**Oh Susannah**") in his ninth symphony.
20. Folk songs were composed by (**famous** or **unknown**) people.
21. The trumpet is a (**brass** or **percussion**) instrument.
22. An (**overture** or **interval**) is played before the curtain opens.
23. Chopin was born in (**Poland** or **Canada**) during the Romantic Era.
24. The music alphabet is (**5** or **7**) letters.

PLACE THE NUMBER OF THE INSTRUMENT IN THE BLANK BY ITS NAME

20

_____ CLARINET

_____ FLUTE

_____ TRUMPET

_____ FRENCH HORN

_____ VIOLIN

_____ HARPSICHORD

_____ TROMBONE

_____ DRUM

_____ OBOE

_____ HARP

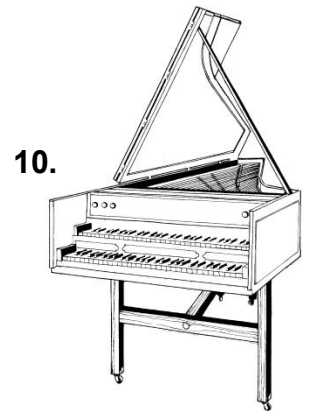
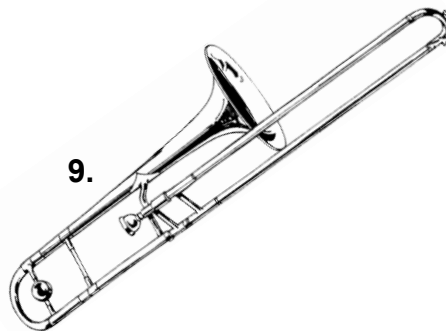
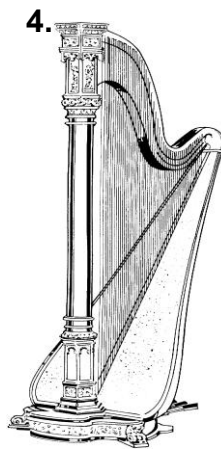

CIRCLE THE CORRECT ANSWER

1. Circle the Romantic composer,
Frederic Chopin.



2. Tchaikovsky introduced this new instrument called the (**CELESTA** or **PIANO**) for his ballet. It has no strings. Instead, steel bars are hit to produce sounds. CIRCLE the correct word.



3. This is a (**MAJOR** or **MINOR**) five finger pattern.

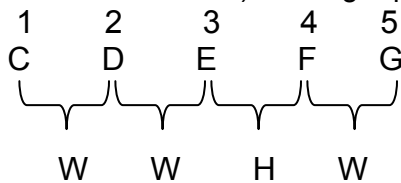

4. This is a (**SEQUENCE** or **TRIAD**).



5. These ladies are dancing in the (**Water Music Suite** or **Nutcracker**).



6. Circle the BOX with the **MINOR TRIAD**.

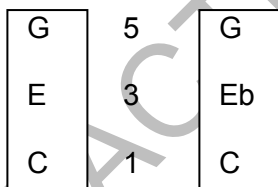

7. Are these (**WHOLE STEPS** or **HALF STEPS**)?

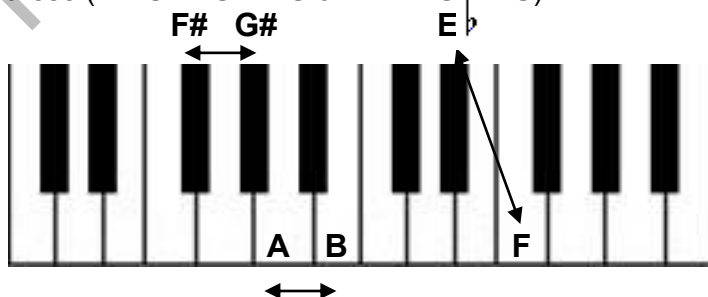

CIRCLE THE CORRECT ANSWER:

8. Circle the interval of a **FIFTH (5TH)**.

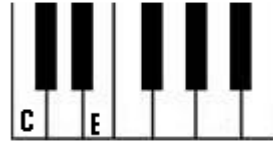
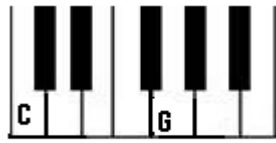

9. This is a (**minor** or **Major**) five finger position.

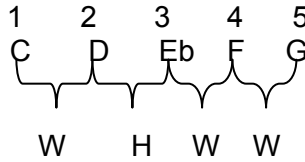

10. Circle the **UPBEAT** in the phrase below.



11. Circle the interval of a **THIRD (3rd)**.

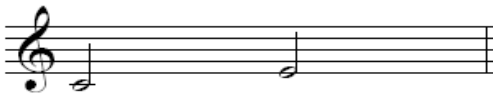

12. Circle the **"TOM-TOM"** rhythms.

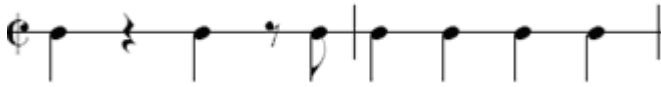

13. Circle the measure that is an **exact repetition** of the motive in the first measure. Do **NOT** circle the first measure.



14. Circle the **harpsichord**.



15. This character is from:

A. Handel's *Water Music Suites*

or

B. *The Nutcracker*, a ballet by Tchaikovsky



16. What is the lowest note? (CIRCLE ONE): **G** or **C**

